



# ELECTRIC PROFESSIONAL SLICERS

S.R.L.

VIA GIOVANNI XXIII, 11 — 22072 CERMENATE (COMO) ITALY — TEL.: +39 031 722 819 — FAX: +39 031 722 825

www.rgv.it — E-mail: info@rgv.it

E-mail USA e CANADA: ferzuc@yahoo.com — E-mail ARGENTINA: expoezeq@arnet.com.ar



## SERIE DOLLY

Mod. **220/S**

Mod. **250/S**

### TECHNICAL CHARACTERISTICS

- Cast aluminium structure **anodized base** ● Tempered professional blade
- Blade cover, tray and bulkhead: in anodized aluminium ● Fixed blade protection ring
- Shaft holding the blade mounted on a double ball-bearing ● Protection on the tray in transparent material
- Professional ventilated motor 230V - 50Hz ● Slicing thickness up to 14 ÷ 16 mm
- Different voltage by request ●

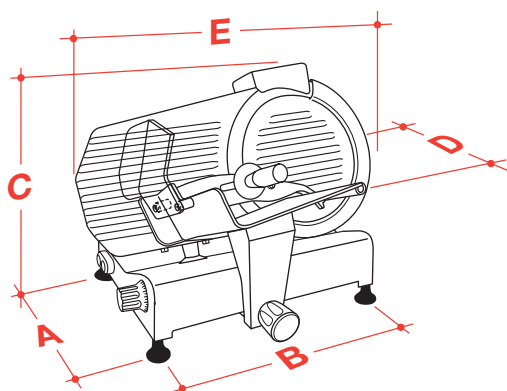

MOD.	220/S	250/S	
A mm	260	260	
B mm	400	400	
C mm	355	365	
D mm	400	410	
E mm	425	475	
Blade diameter (Ø)	mm	220	250
Motor power	Watt	140	140
Capacity of cutting about	mm	210 x 155	210 x 175
Carriage stroke	mm	245	245
Gross weight	kg	15	15,5
Packing dimensions	cm	48 x 53 x 39	48 x 53 x 39
	m <sup>3</sup>	0,1	0,1